

SOLLEVATORI PER VEICOLI
VEHICLE LIFTS



T5/2 - T7



I ponti OMER sono omologati od approvati dai maggiori enti di controllo internazionali. Ogni violazione dei diritti della OMER sarà perseguita a norma di legge. Ogni dato tecnico esposto nel presente catalogo è soggetto alle modifiche che la casa costruttrice si riserva di apportare in qualunque momento senza preavviso e senza alcuna responsabilità ed obbligo a carico della O.M.E.R.

OMER Lifts are homologated or approved by the major international controlling bodies. Any violation of OMER's rights shall be prosecuted according to law. The manufacturer reserves the right to change the product specifications without notice and liability.

OMER Hebebühnen sind von den bekanntesten internationalen Prüfstellen abgenommen und entsprechen deren Kriterien. Jede Verletzung der OMER Rechte wird gesetzlich verfolgt. Die Firma O.M.E.R. behält sich das Recht vor, alle Änderungen an den oben angeführten technischen Daten ohne vorherige Benachrichtigung und ohne jegliche Verantwortung oder Verpflichtung vorzunehmen.

Les ponts OMER sont agréés par les plus grands organismes de contrôle internationaux. Toutes copies ou violations des brevets seront poursuivies.

Toutes données techniques exposées dans ce catalogue sont tributaires de modifications que la Maison constructrice se réserve d'apporter n'importe quel moment et ceci sans aucun préavis et sans aucune responsabilité et obligation de la part de la Maison O.M.E.R.

Los puentes elevadores OMER están homologados o aprobados por los institutos internacionales de control más importantes. Todos los derechos están reservados y la violación de los mismos está penada por la Ley.

O.M.E.R. se reserva el derecho de modificar en cualquier momento, sin aviso previo y sin ninguna responsabilidad ni compromiso, todos los datos técnicos indicados en el presente catálogo.

T5/2

Traversa con 2 martinetti idraulici, indipendente - Traverse with 2 hydraulic jacks, self powered
Traverse mit 2 hydraulischen Wagenheber, mit unabhängigem Antrieb
Traverse avec 2 crics hydrauliques, indépendante - Traversa con 2 gatos hidraulicos, independiente

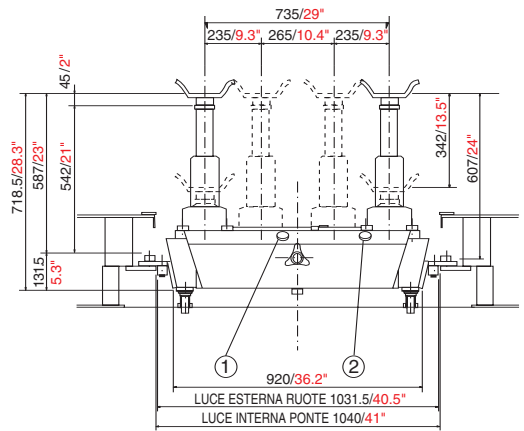
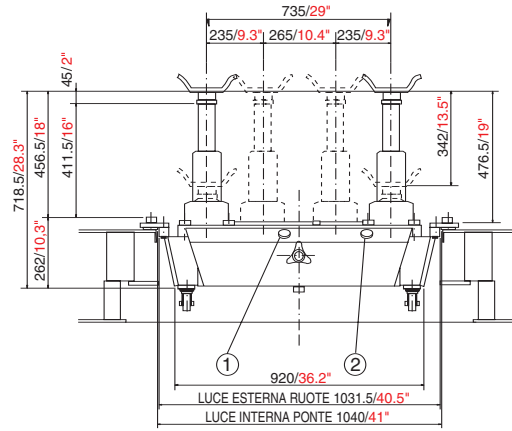

Scorrimento sopra corsie - Sliding on runways
Gleiten auf der Fahrbahnen
Patinage sur les chemins de roulement
Desliz sobre plataformas.

Scorrimento su interno corsie - Sliding on inner rails
Gleiten in der inneren Seite der Fahrbahnen
Patinage dans l'intérieur des chemins de roulement
Desliz en el interior de las plataformas

MM / KG INCH / LBS	Capacità Capacity Tragkraft Capacité Capacidad	Alimentazione elettrica - Electric feed - Elektrische Speisung Alimentation électrique - Alimentación eléctrica	Pressione olio Oil pressure Betriebsdruck Pression d'huile Presión aceite	Quantità olio Oil capacity Hydraulikölmenge Reservoir d'huile Cant. aceite	Peso Gross Weight Gesamtgewicht Poids Peso	Tempo di salita Lifting time Hubzeit Temps de levée Tiempo de subida
T5/2	20000 kg 44000 lbs	230-400V/3/50 Hz 1.5 kW	195 Bar	8 l.	230 Kg 500 lbs	10 s



O.M.E.R. Spa Via G. Galilei, 20
30035 Mirano Venezia ITALY
Tel. +39 041 5700303
Fax +39 041 5700273
E-mail: info@omerlift.com
www.omerlift.com



T7

Traversa - Traverse
Traverse - Traversa
Traversa

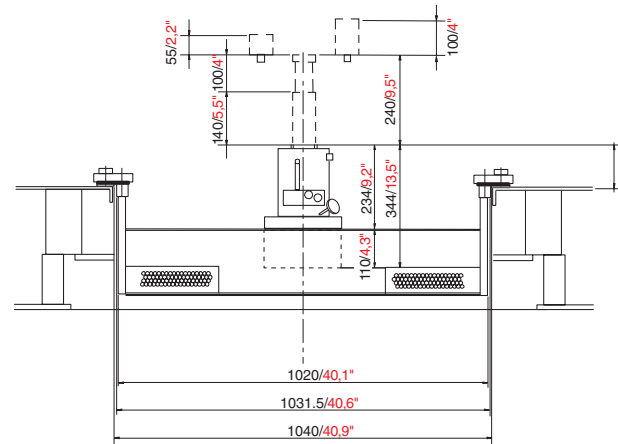

Capacità Capacity Tragkraft Capacité Capacidad
T7 20000 kg 44000 lbs

Scorrimento sopra corsie.
Sliding on runways.
Gleiten auf der Fahrbahnen.
Patinage sur les chemins de roulement.
Desliz sobre plataformas.

Inserimento nella Traversa di max. 2 cricchi P200F - Installation inside the Traverse of max. 2 jacks P200F
Max. Einbau in der Traverse von 2 Wagenheber P200F - Installation dans la Traverse de max. 2 crics P200F
Instalación en la Traversa max 2 gatos P200F

P200F

Cricco pneumatico - Pneumatic Jack
Pneumatischer Wagenheber - Cric pneumatique -
Gato pneumático



	Capacità Capacity Tragkraft Capacité Capacidad	Peso Gross weight Gesamtgewicht Poids Peso	Alimentazione Pneumatica Air operated feed Pneumatik Versorgung Alimentation pneumatique Alimentación Neumatica
P200F	10000 Kg. 22000 lbs	28 Kg. 62 lbs	6 ÷ 10 Bar

